

CD/MP3/WMA/AAC Audio Controller

Features

- Super on-chip Integration for low cost and low count bill of materials
- 32-Bit RISC Processor performs audio decode and system management functions
- 16-bit DSP for audio special effects
- 80 Kbytes internal SRAM, and 256 Kbytes internal ROM
- Interfaces to external SDRAM or EDO DRAM (for shock protection), and to external ROM/FLASH (for custom program storage)
- CD serial interface with advanced pattern matching and software error handling
- Integrated DAC functionality
- Simultaneous 4 channels PCM audio output and IEC-958 output.
- Large number of GPIO pins for servo control, key scan, LCD control, etc.
- Three serial control/status ports
- Sophisticated clock management and low power consumption
- Supports ISO9660 and multi-session write methods
- Low power 0.18 micron technology
- 100-pin LQFP package
- Lead-free/industrial temperature range parts available

Description

The CS7410 is a true system-on-a-chip for the CD-based digital audio market. With a powerful RISC processor, one DSP, integrated audio $\Delta\Sigma$ modulator, large internal SRAM and program ROM, and glueless interface to popular CD chip sets, the CS7410 is a complete single chip low-power programmable audio decoder. This powerful architecture is easily capable of MP3, WMA, AAC™ and other future audio formats. The CS7410's flexible architecture and low power consumption make it an ideal low-cost solution for a wide range of player applications. For portable audio systems, the memory interface can be used to add DRAM or SRAM for Electronic Shock Protection (ESP). A flexible set of interfaces are available for end-user I/O such as a keypad and LCD control for use in mass market CD players, boom boxes, and shelf-top systems.

ORDERING INFORMATION

CS7410-CQ	0° to 70° C	100-pin LQFP
CS7410-IQZ	-40° to 85° C	100-pin LQFP

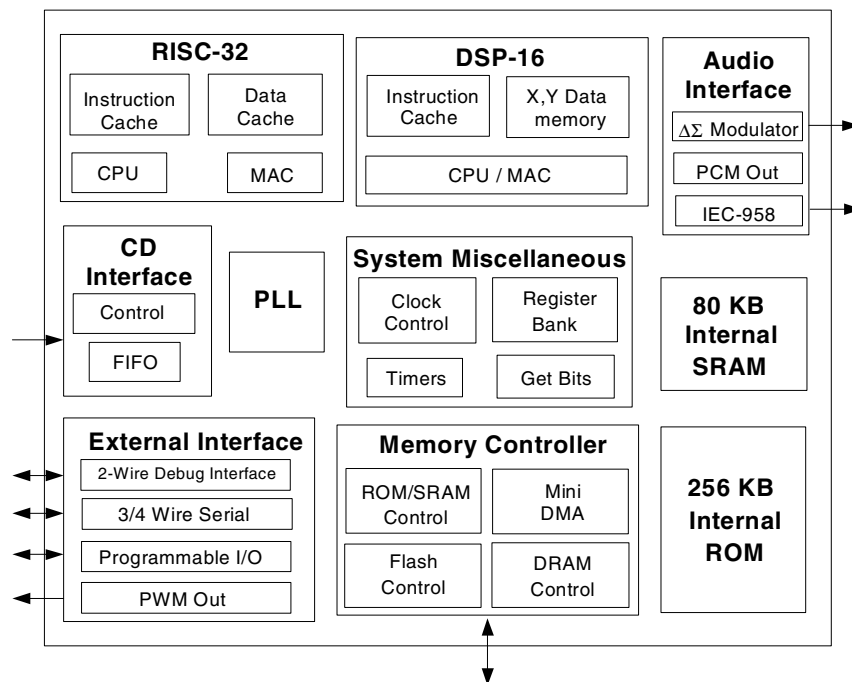

Preliminary Product Information

This document contains information for a new product. Cirrus Logic reserves the right to modify this product without notice.

TABLE OF CONTENTS

1. CHARACTERISTICS AND SPECIFICATIONS	4
1.1 AC AND DC PARAMETRIC SPECIFICATIONS	4
1.1.1 Absolute Maximum Rating	4
1.1.2 RECOMMENDED OPERATING CONDITIONS	4
1.1.3 Electrical Specifications	5
1.1.4 DC CHARACTERISTICS	6
1.1.4.1 SDRAM Interface	6
1.1.4.2 Serial Interface	9
1.1.4.3 EDO DRAM Interface	10
1.1.4.4 FLASH / ROM Interface	12
1.1.4.5 Audio Output Interface	14
1.1.4.6 CD Interface	15
1.1.4.7 Miscellaneous Timings	17
2. CS7410 SUMMARY	18
2.1 CS7410 Typical Application	18
2.2 CS7410 Block Summaries	18
2.2.1 RISC-32	18
2.2.2 DSP-16	18
2.2.3 System Controls	19
2.2.4 Memory System	19
2.2.5 CD Interface	19
2.2.6 Audio Interface	19
2.2.7 External Interface	19
2.2.8 System Functions	19
3. FUNCTIONAL DESCRIPTION	20
3.1 RISC-32 Processor	20
3.2 DSP-16 Processor	20
3.3 Memory Control	20
3.4 CD Interface	20
3.5 System Control Functions	21
3.6 Audio Output	21
4. PIN DESCRIPTION	22
4.1 Pin Identification	22
4.2 Miscellaneous Pins	26
4.3 Serial Interface Pins	26
4.4 SDRAM / DRAM Interface	27
4.5 ROM/NVRAM Interface	29
4.6 Digital Audio Output Interface	30
4.7 $\Delta\Sigma$ Modulator Interface	30
4.8 CD Interface	31
4.9 General Purpose Input/Output (GPIO)	32
4.10 Power and Ground	33
5. 100-PIN LQFP PACKAGE SPECIFICATIONS (14 X 14 X 1.4 MM)	34
6. REVISION HISTORY	35

LIST OF FIGURES

Figure 1. SDRAM Timing	6
Figure 2. SDRAM Load Mode	7
Figure 3. SDRAM Burst Write	7
Figure 4. SDRAM Burst Read	8
Figure 5. SDRAM Refresh	8
Figure 6. Serial Interface Timing Diagram	9
Figure 7. EDO Page Write Timing Diagram	11
Figure 8. EDO Page Read Timing Diagram	11
Figure 9. EDO Refresh Timing Diagram	11
Figure 10. FLASH/ROM Read	12
Figure 11. FLASH/ROM Write	13
Figure 12. Audio Output Timing	14
Figure 13. CD Interface Timing	15
Figure 14. CD Interface Timing Diagrams	16
Figure 15. Miscellaneous Timings	17
Figure 16. CS7410 Application	18
Figure 17. CS7410 Pin Identification	22
Figure 18. 100-Pin LQFP Package (14 X 14 X 1.4 mm)	34

LIST OF TABLES

Table 1. SDRAM Characterization Data	6
Table 2. Serial Interface Characterization Data	9
Table 3. EDO DRAM Characterization Data	10
Table 4. FLASH/ROM Read Characterization Data	12
Table 5. Audio Output Interface Symbols and Characterization Data	14
Table 6. Pin Type and Direction Legend	22
Table 7. Pin Assignments	23
Table 8. Miscellaneous Interface Pins	26
Table 9. Serial Interface Pins	27
Table 10. SDRAM Interface	27
Table 11. EDO DRAM Interface	28
Table 12. ROM/NVRAM Interface	29
Table 13. Audio Output Interface	30
Table 14. $\Delta\Sigma$ Output Interface	30
Table 15. CD Interface	31
Table 16. Dedicated General Purpose I/O Pins	32
Table 17. Redefined General Purpose Pins	32
Table 18. Power and Ground	33
Table 19. Revision History	35

1. CHARACTERISTICS AND SPECIFICATIONS

1.1 AC AND DC PARAMETRIC SPECIFICATIONS

(AGND, DGND=0V, all voltages with respect to 0V)

1.1.1 Absolute Maximum Rating

Symbol	Description	Min.	Max.	Unit
VDD _{IO}	Power Supply Voltage on I/O ring	-0.5	4.6	Volts
VDD _{CORE}	Power Supply Voltage on core logic and PLL	-0.5	2.5	Volts
V _I	Digital Input Applied Voltage (power applied)	-0.5	5.5	Volts
I _I	Digital Input Forced Current	-10	10	mA
I _O	Digital Output Forced Current	-50	50	mA
T _{SOL}	Lead Soldering Temperature	-	+260	°C
T _{VSOL}	Vapor Phase Soldering Temperature	-	+235	°C
T _{STOR}	Storage Temperature (no power applied)	-40	+125	°C
T _{AMB}	Ambient Temperature (power applied) - commercial (-C)	0	+70	°C
T _{AMB}	Ambient Temperature (power applied) - industrial (-I)	-40	+85	°C
P _{TOT}	Power consumption	-	1	W

CAUTION: Operating beyond these Minimum and Maximum limits can result in permanent damage to the device. Cirrus Logic recommends that CS7410 devices operate at the settings described in the next table.

1.1.2 RECOMMENDED OPERATING CONDITIONS

Parameter	Symbol	Min	Typ	Max	Units
Supply Voltage, IO	V _{DD}	3.0	3.3	3.6	Volts
Supply Voltage, core and PLL	V _{DD}	1.62	1.8V	1.98	Volts
Ambient Temperature - Commercial (-C part number) (power applied)	T _{AMB}	0	-	+70	°C
Ambient Temperature - Industrial (-I part number) (power applied)	T _{AMB}	-40	-	+85	°C

1.1.3 Electrical Specifications

(TA = 0 to +70 °C for the commercial part (-C part number), TA = -40 to +85 °C for the industrial part (-I part number))

Parameter	Symbol	Conditions	Min	Typ	Max	Units
Power Supply						
Supply Current, IO	I_{DD}	Normal Operating, Playing MP3 Disc	-	13	-	mA
Supply Current, core and PLL	I_{DD}	Normal Operating, Playing MP3 Disc	-	70	-	mA
Digital Pins						
Input Voltage, High	V_{IH}	-	2.0	-	-	Volts
Input Voltage, Low	V_{IL}	-	-	-	0.8	Volts
Input Current	I_{IN}	$V_{IN} = V_{DD}$ or V_{SS}	-1	-	+1	μ A
Input Pull up/down resistor	R_I	-	-	75	-	K Ω
Output Voltage, High	V_{OH}	@ buffer rating	2.4	-	-	Volts
Output Voltage, Low	V_{OL}	@ buffer rating	-	-	0.4	Volts
High-Z-state Leakage	I_{OZ}	$V_{OUT} = V_{SS}$ or V_{DD}	-1	-	+1	μ A

1.1.4 DC CHARACTERISTICS

(VDD_PLL=VDD_CORE=1.8V±10%, VDD_IO=3.3V±10%)

1.1.4.1 SDRAM Interface

Symbol	Description	Min	Typ	Max	Unit
t_{mper}	DR_CKO Period	22 ^a	-	-	ns
t_{mco}	Output Delay from DR_CKO active edge	-	-	19	ns
t_{mdow}	M_D[15:0] delay from DR_CKO	-	-	19	ns
t_{mhw}	M_D[15:0] valid time after DR_CKO	5	-	-	ns
t_{msur}	M_D[15:0] setup to DR_CKO	13	-	-	ns
t_{mhr}	M_D[15:0] hold time after DR_CKO	0	-	-	ns

Table 1. SDRAM Characterization Data

a. Guaranteed by Design

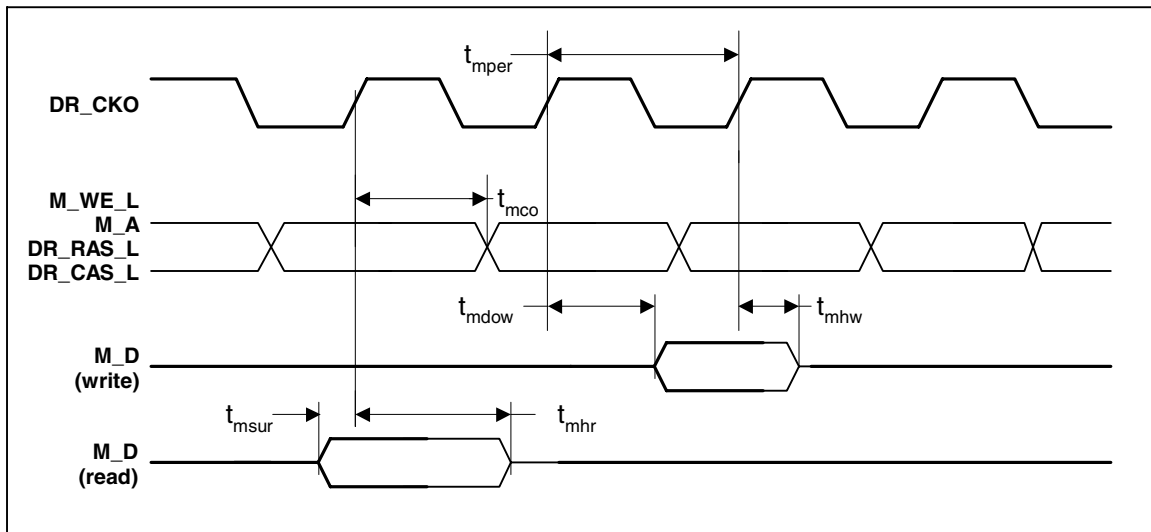

Figure 1. SDRAM Timing

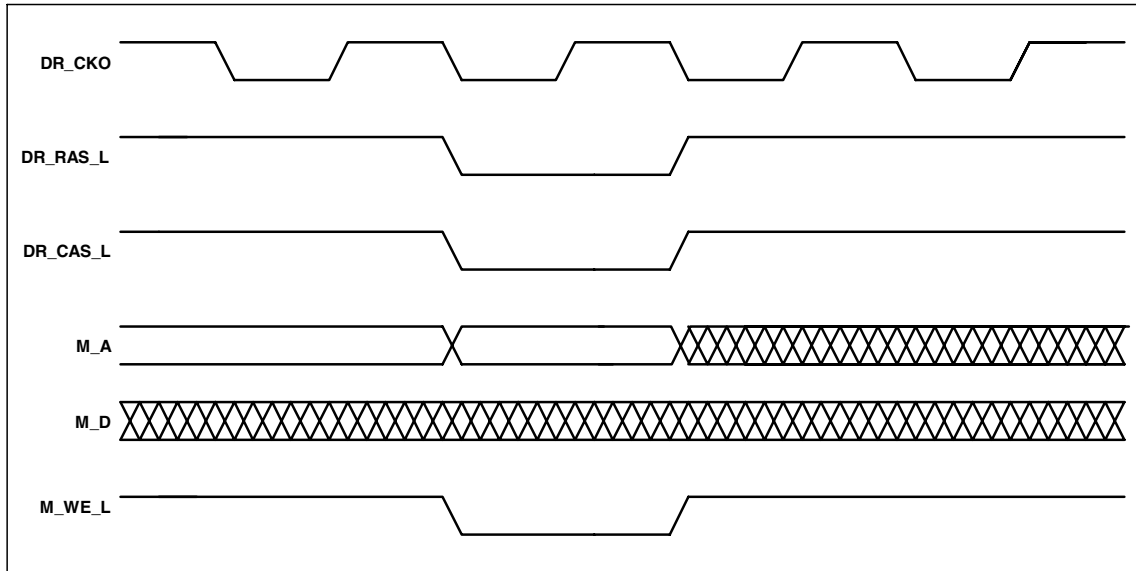

Figure 2. SDRAM Load Mode

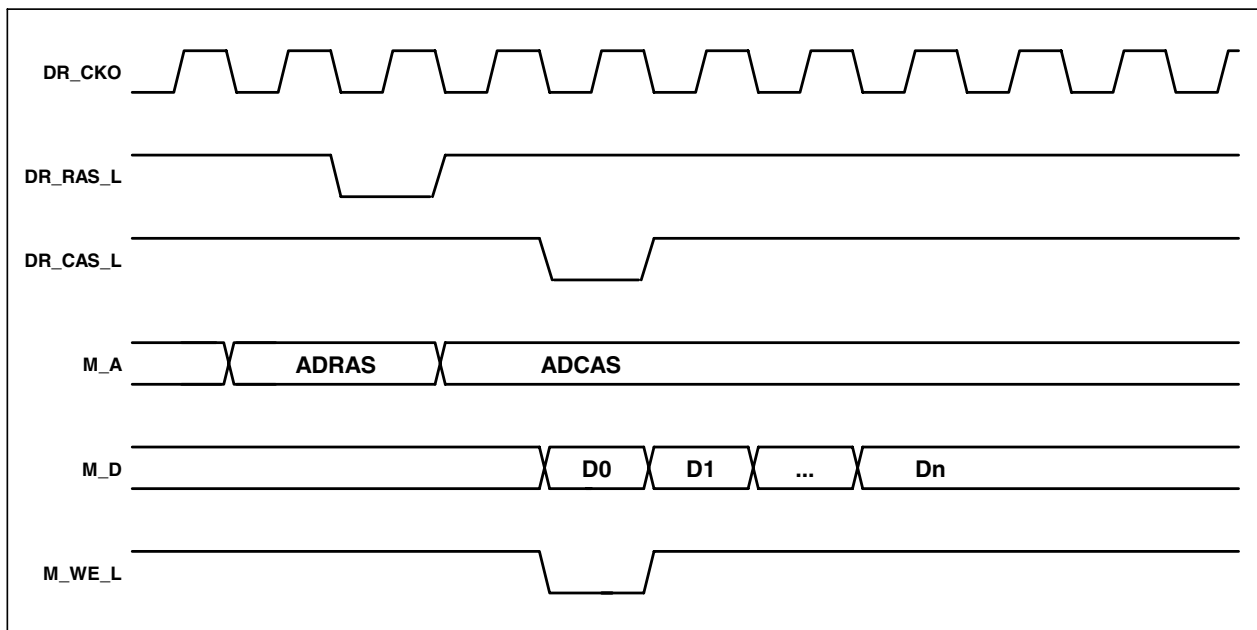

Figure 3. SDRAM Burst Write

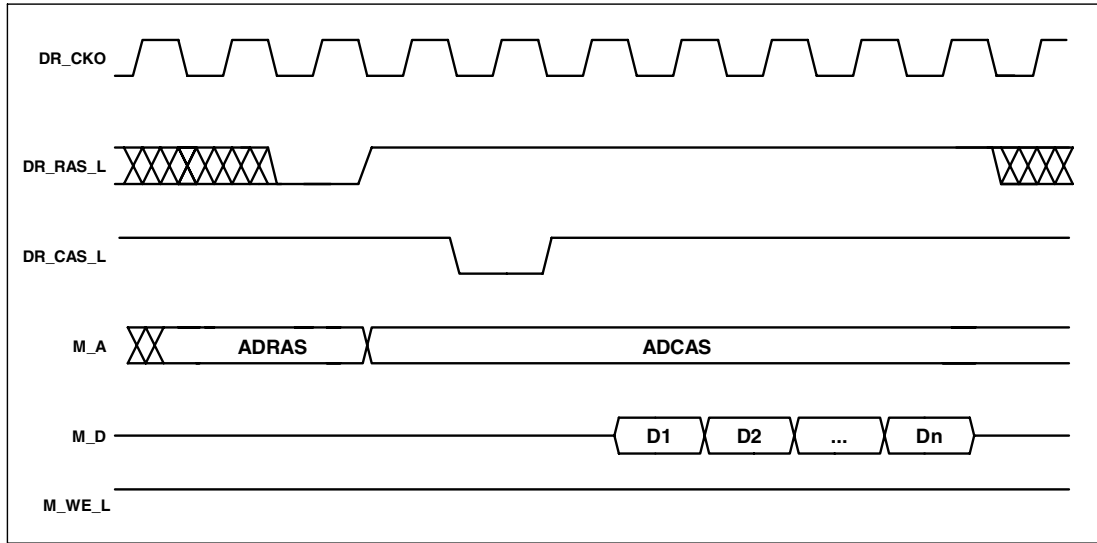

Figure 4. SDRAM Burst Read

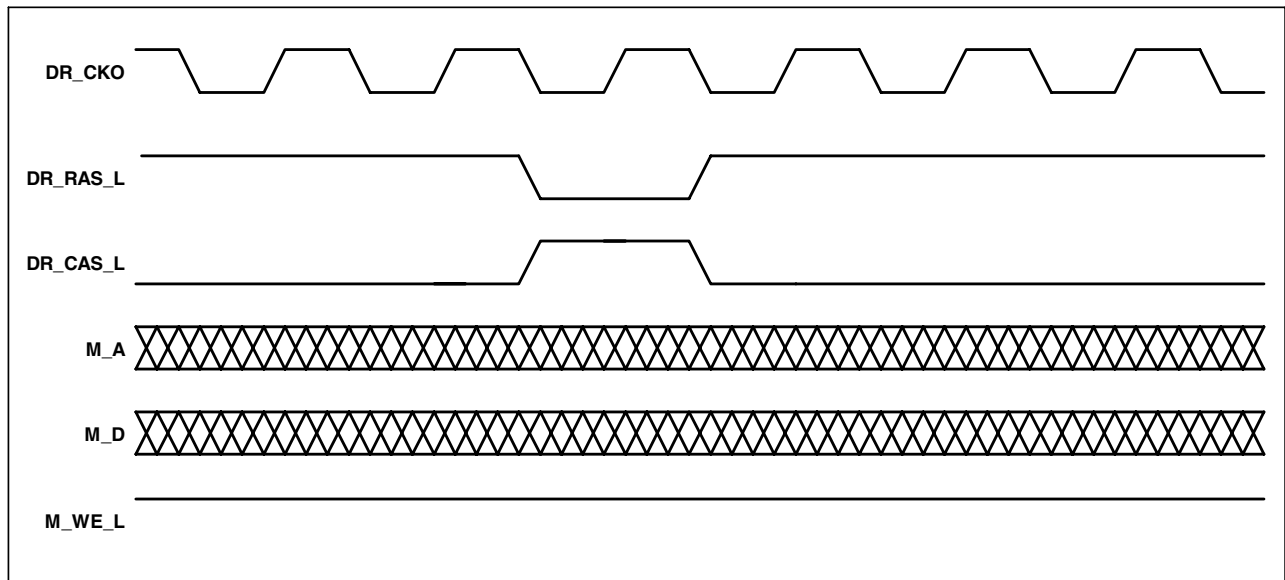

Figure 5. SDRAM Refresh

1.1.4.2 Serial Interface

Symbol	Description	Min	Typ	Max	Unit
t_{clk_per}	Clock period	66 ^a	-	-	ns
t_{DMs}	Master-mode data setup	28	-	-	ns
t_{DMh}	Master-mode data hold	28	-	-	ns
t_{DSs}	Slave-mode data setup	15	-	-	ns
t_{CMs}	Master chip select to clock setup	28	-	-	ns
t_{DSh}	Slave mode data hold	0	-	-	ns

Table 2. Serial Interface Characterization Data

a. Guaranteed by Design

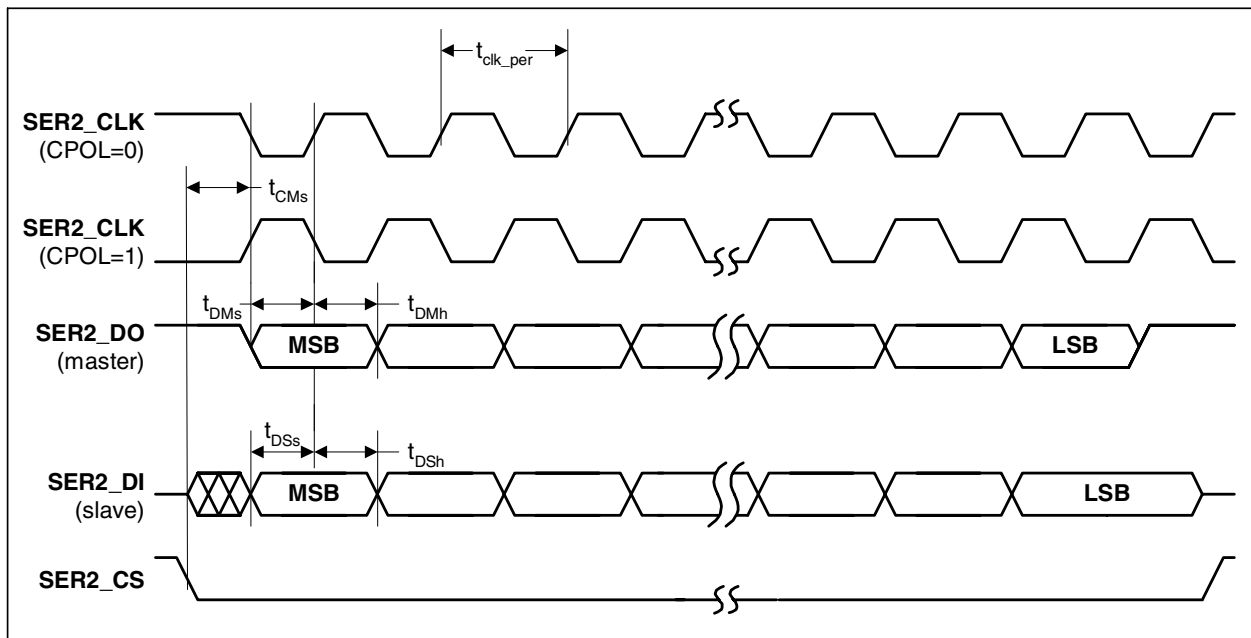
Figure 6. Serial Interface Timing Diagram

1.1.4.3 EDO DRAM Interface

Symbol	Description	Min	Typ	Max	Unit
t_{RAS}	RAS low time	72	-	-	ns
t_{RP}	RAS high pulse time	40	-	-	ns
t_{RCL}	RAS fall to CAS fall	38	-	-	ns
t_{CAS}	CAS low time	30	-	-	ns
t_{CPN}	CAS high time	15	-	-	ns
t_{CAH}	CAS fall to address row	29	-	-	ns
t_{ASR}	Address row to RAS fall	10	-	-	ns
t_{RAH}	RAS fall to address column	18	-	-	ns
t_{ASC}	second address column (burst) to CAS fall	10	-	-	ns
t_{AA}	Column address to data setup	-	-	35	ns
t_{CAC}	CAS fall to data setup	-	-	17	ns
t_{CSR}	CAS fall to RAS fall	19	-	-	ns
t_{CHR}	RAS fall to CAS rise	18	-	-	ns
t_{CRH}	CAS rise to RAS rise	6	-	-	ns
t_{WDS}	Write data setup to CAS fall	12	-	-	ns
t_{WDH}	Write data hold to CAS fall	29	-	-	ns
t_{WS}	Write enable setup to CAS fall	13	-	-	ns
t_{WH}	Write enable hold to CAS fall	20	-	-	ns
t_{ROE}	RAS fall to OE fall	-5	-	5	ns
t_{OER}	RAS rise to OE rise	-5	-	5	ns
t_{DCH}	Read data hold to CAS rise	0	-	-	ns

Table 3. EDO DRAM Characterization Data

Note: Values shown are for minimum internal clock period (11 ns) and all programmed wait states enabled.

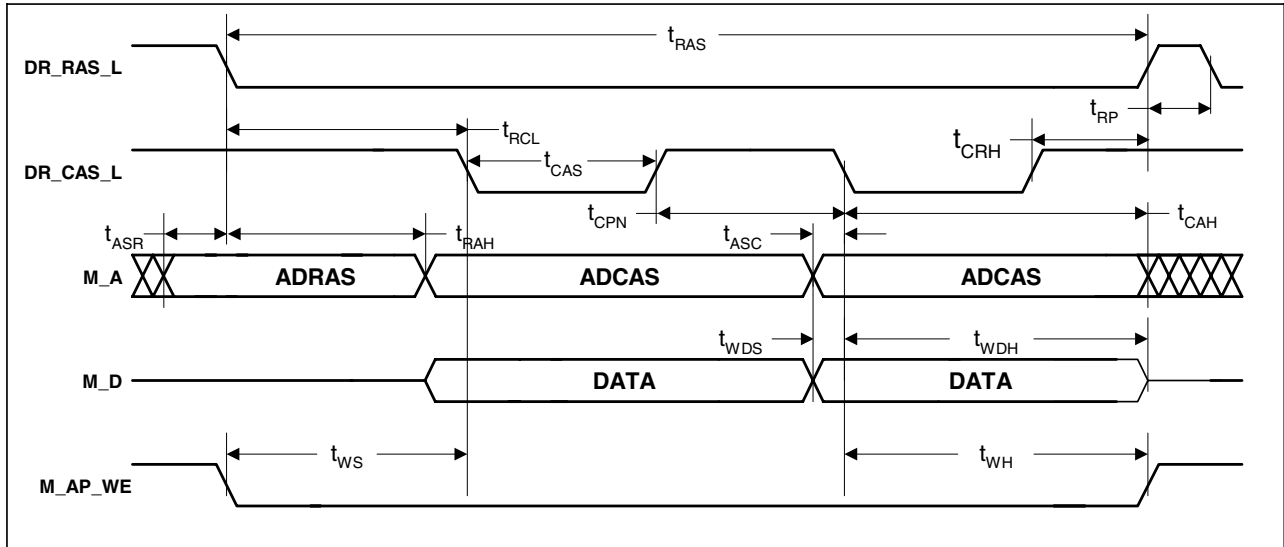

Figure 7. EDO Page Write Timing Diagram

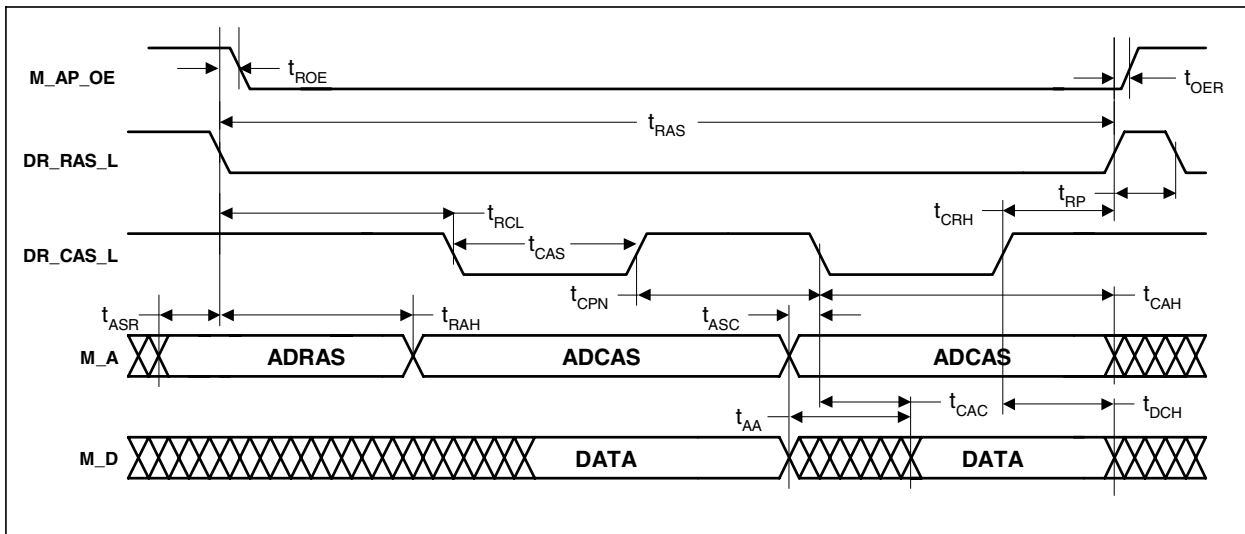

Figure 8. EDO Page Read Timing Diagram

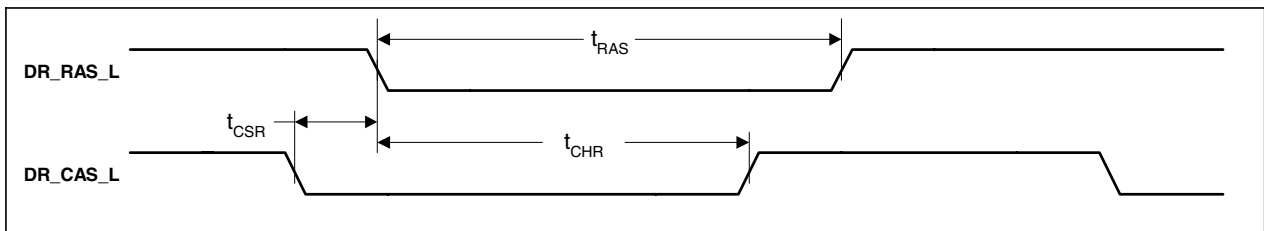

Figure 9. EDO Refresh Timing Diagram

1.1.4.4 FLASH / ROM Interface

Symbol	Description	Min	Typ	Max	Unit
t_{CSpw}	CE low period	135	-	-	ns
t_{RDd1}	CE fall to output enable fall	5	-	-	ns
t_{RDd2}	CE rise to output enable rise	-5	-	5	ns
t_{ADs}	Address setup to CE fall	-10	-	10	ns
t_{DAs}	Data setup after address ^a	-	-	28	ns
t_{WRSU}	All outputs setup before WE	95	-	-	ns
t_{WRPW}	WE pulse width	170	-	-	ns
t_{WRH}	All outputs hold after WE	95	-	-	ns

Table 4. FLASH/ROM Read Characterization Data

a. Value shown for 3 programmed wait states.

Note: Values shown are for minimum internal clock period (11 ns) and no programmed wait states.

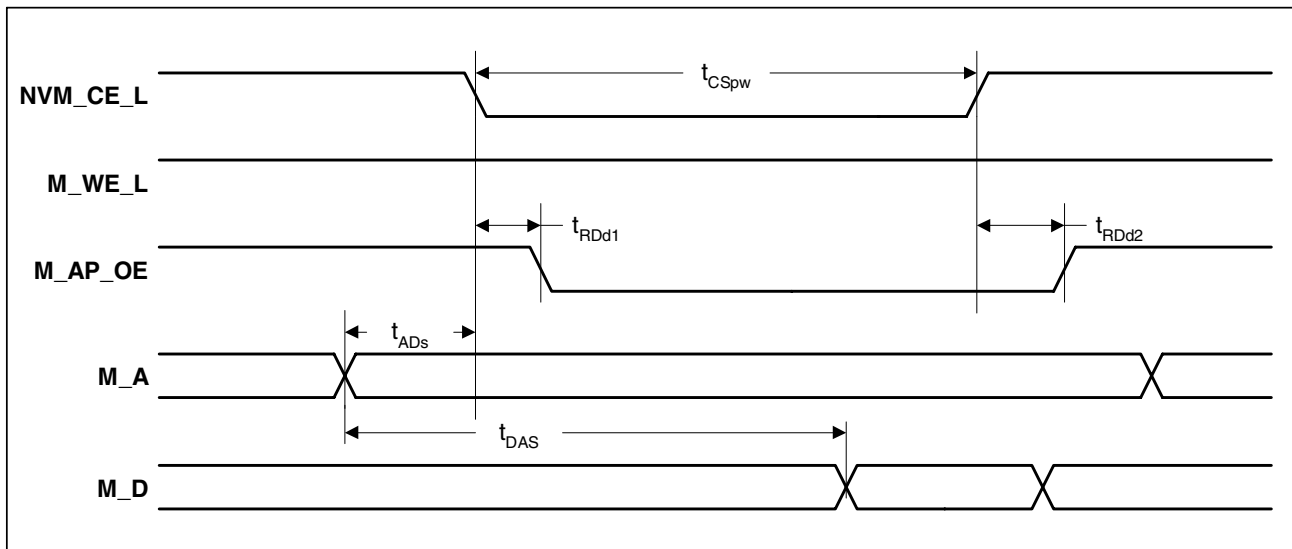
Figure 10. FLASH/ROM Read

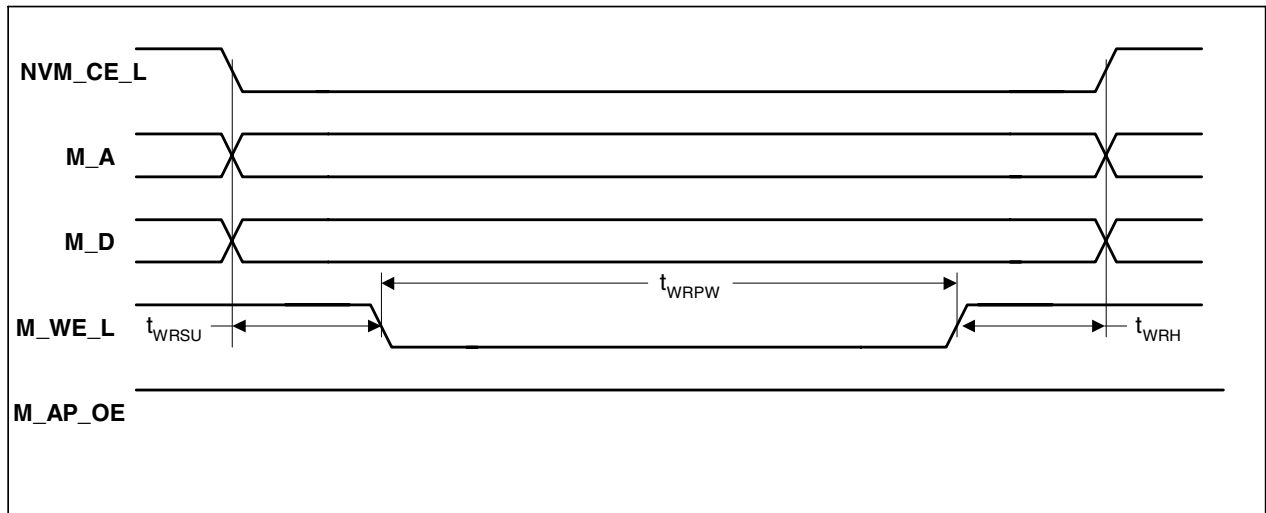

Figure 11. FLASH/ROM Write

1.1.4.5 Audio Output Interface

Symbol	Description	Min	Typ	Max	Units
t_{axch}	PCM_XCLK High Time (PCM_XCLK is Input/Output) ^a	42	50	-	%
t_{axcl}	PCM_XCLK Low Time (PCM_XCLK is Input/Output) ^a	42	50	-	%
t_{axper}	PCM_XCLK period (Input/Output) ^a	55	-	-	ns
t_{aoper}	PCM_BCK period (Output) ^a	440	-	-	ns
t_{sdmo}	PCM_BCK delay from PCM_XCLK output transition ^b	-	-	7	ns
t_{sdmi}	PCM_BCK delay from PCM_XCLK input transition ^b	-	-	15	ns
t_{lrds}	PCM_LRCK delay from PCM_BCK transition ^b	-	-	7	ns
t_{adsm}	PCM_D[3:0] delay from PCM_BCK transition ^b	-	-	7	ns

Table 5. Audio Output Interface Symbols and Characterization Data

a. Guaranteed by Design

b. Active clock edge is programmable. Timing is referenced from the active edge.

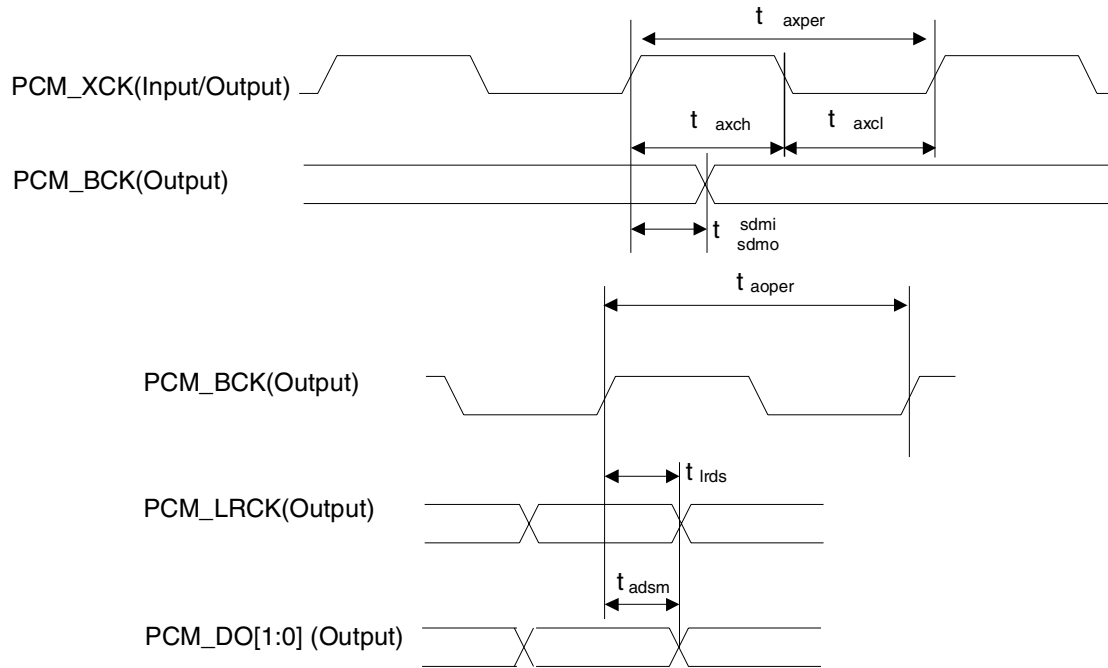

Figure 12. Audio Output Timing

1.1.4.6 CD Interface

Symbol	Description	Min	Typ	Max	Units
t_{slri}	CD_LRCK setup to CD_BCK active edge	7	-	-	ns
t_{sdi}	CD_DATA and CD_C2P0 setup to CD_BCK active edge	7	-	-	ns
t_{hdsi}	CD_DATA and CD_C2P0 hold time after CD_BCK active edge	3	-	-	ns

Note: Active edge of CD_BCLK is programmable

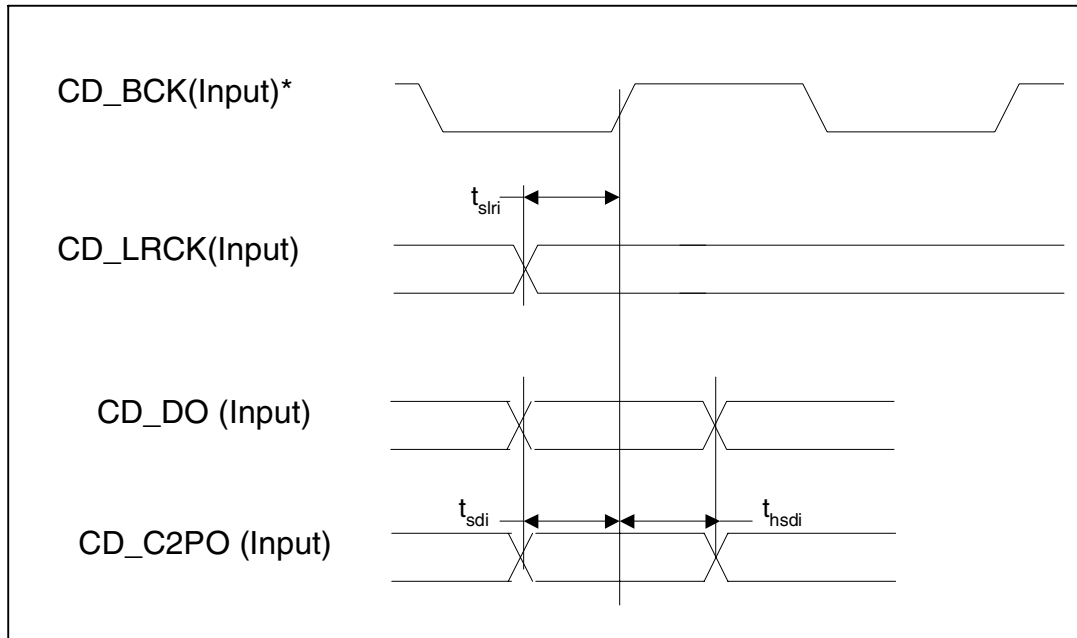
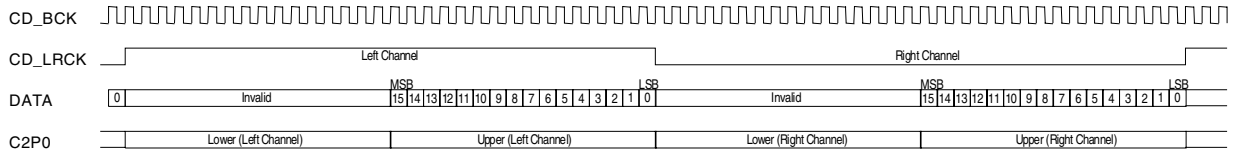
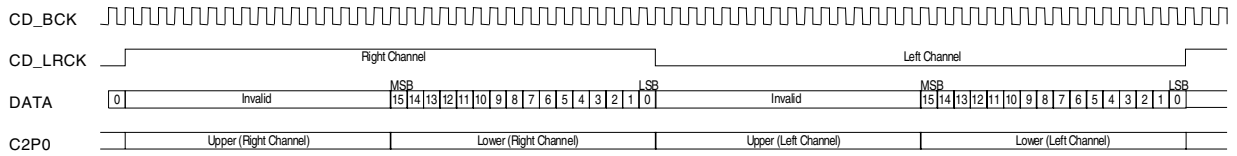

Figure 13. CD Interface Timing



32-bit BCK, MSB First, Right Channel Low, C2P0 LSB First, Data latch timing high



32-bit BCK, MSB First, Left Channel Low, C2P0 MSB First, Data latch timing low

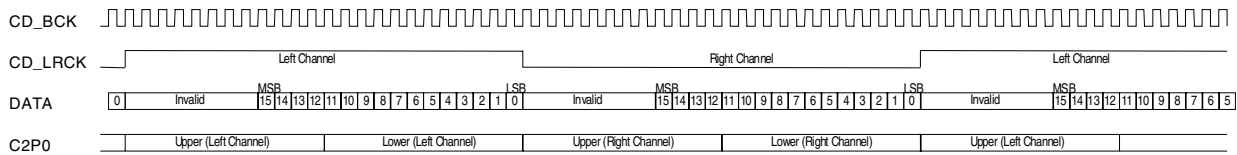

24-bit BCK, MSB First, Right Channel Low, C2P0 MSB First, Data latch timing high

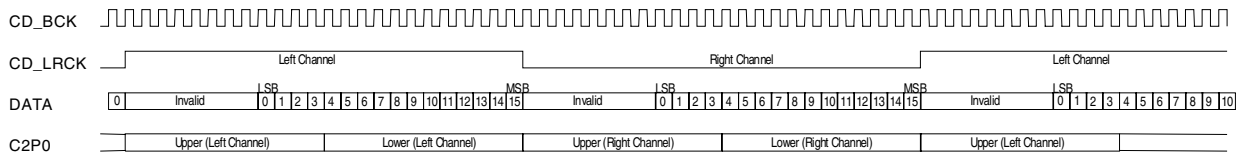

24-bit BCK, LSB First, Right Channel Low, C2P0 MSB First, Data latch timing low

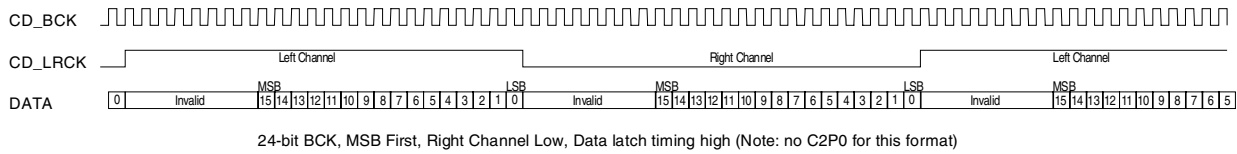

24-bit BCK, MSB First, Right Channel Low, Data latch timing high (Note: no C2P0 for this format)

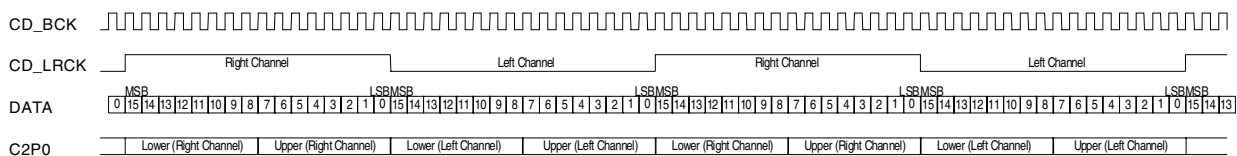

16-bit BCK, MSB First, Left Channel Low, C2P0 LSB First, Data latch timing high

Figure 14. CD Interface Timing Diagrams

1.1.4.7 Miscellaneous Timings

Symbol	Description	Min	Typ	Max	Unit
t_{xclper}^a	XTLCLK period	-	59.05	-	ns
t_{rstl}	RST_N Low Pulse Width	1000	-	-	ns
t_{gph}	GPIO PW High	50	-	-	ns
t_{gpl}	GPIO PW Low	50	-	-	ns

a. Value represents typical application with 16.934 MHz crystal

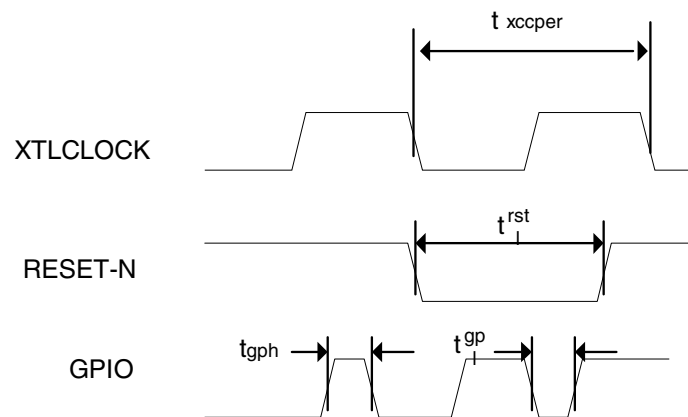

Figure 15. Miscellaneous Timings

2. CS7410 SUMMARY

2.1 CS7410 Typical Application

Figure 16 shows an example of a complete audio player using the CS7410.

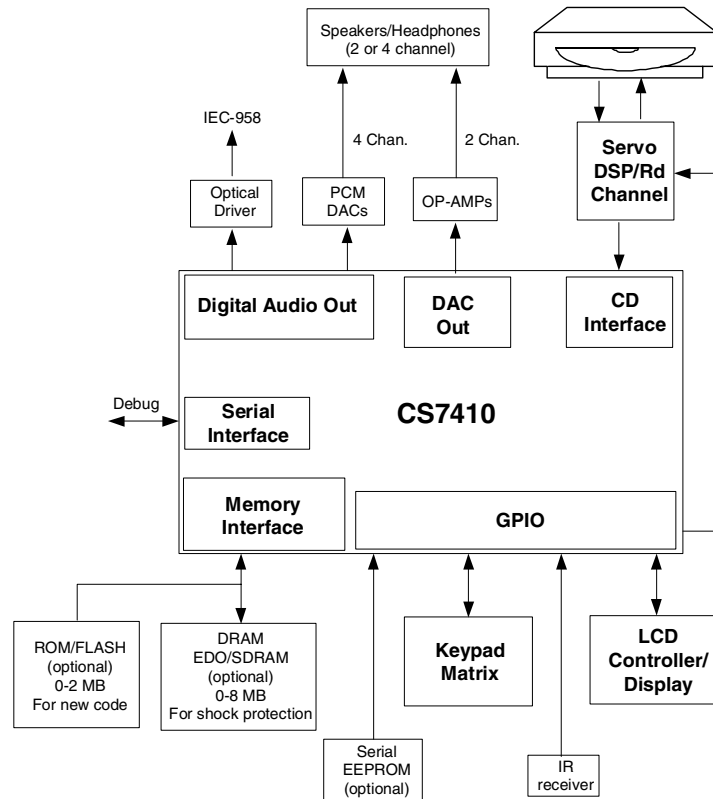

Figure 16. CS7410 Application

2.2 CS7410 Block Summaries

2.2.1 RISC-32

- Powerful 32-bit RISC processor
- Comprehensive development tool support
- Big or little endian data formats supported
- 32x32 (64-bit result) MAC, 2 cycles / multiply with C support
- 4 Kbyte instruction cache, 2 Kbyte data cache
- Single cycle instructions, runs up to 90 MHz

2.2.2 DSP-16

- Powerful 16-bit DSP processor
- 16-bit fixed point logic, with 36 bit accumulator.
- Single-cycle throughput, 2-cycle latency multiply accumulate, 16-bit simple integer logic
- 512 byte instruction cache, 8 Kbyte program visible local memory
- Single cycle instructions, runs up to 90 MHz

- DSP MAC is pipelined, 1 cycle / multiply

2.2.3 System Controls

- Includes 32 hardware lockable semaphore registers
- Two general-purpose registers for inter-processor communication
- Three 32-bit timers for I/O and other uses, with programmable interval rates
- “Getbits” module accelerates peripheral stream parsing
- Both hardware and software interrupts on data or debug

2.2.4 Memory System

- Large internal SRAM (80 Kbyte) and internal program ROM (256 Kbyte)
- Supports both Synchronous and EDO DRAM (256 KBytes to 8 MBytes) for ESP
- Supports one bank of FLASH and ROM (up to 2 MBytes) for nonvolatile storage
- 4-, 8-, or 16-bit data bus for DRAM, 8-bit data bus for ROM

2.2.5 CD Interface

- Glueless interfaces to CD servo chip set, supporting all standard CD formats
- Includes pattern matching hardware to support fast ESP recovery

2.2.6 Audio Interface

- Supports 4 channels PCM, I²S connectivity at up to 24 bits
- Flexible audio clocking scheme using internal PLL and dividers, or external pins
- Simultaneous IEC-958 output with programmable channel status and user data
- Integrated sigma-delta ($\Delta\Sigma$) stereo audio modulator

2.2.7 External Interface

- 2-wire serial slave port, used for debug
- 3- or 4-wire synchronous serial master/slave port for external controller or slave peripheral
- Separate synchronous serial master port optimized for receiving CD sub-codes
- Up to 29 programmable bi-directional I/O (GPIO) and up to 9 output only (GPO) pins (some multiplexed with other peripherals)
- All pins defined as GPIOs can be used to receive edge or level detection interrupts.
- Pulse-width modulated (PWM) output pin can be used to create simple ADC using low-cost comparator (i.e., for battery voltage monitor)

2.2.8 System Functions

- Internal oscillator uses external crystal, or receives clock (i.e. 16.9 MHz) from CD servo
- Internal PLL generates any system clock frequency, chip can run up to 90 MHz
- Includes clock divider and clock shutoff circuits for low power/sleep modes
- Advanced 0.18 micron CMOS technology, runs off 1.8 V and 3.3 V
- All I/O pins are 3.3 V, with 5 V tolerance
- 100-pin LQFP package
- Lead-free/industrial temperature range parts available

3. FUNCTIONAL DESCRIPTION

3.1 RISC-32 Processor

The CS7410 includes a powerful, proprietary 32-bit RISC processor backed by powerful software development tools. The RISC-32 has a MIPS-compatible instruction set, as well as a MAC engine which performs multiply/accumulate in 2 cycles with C support, effectively achieving single cycle throughput.

There are other instructions that are designed to help with performing audio decoding. The RISC processor coordinates on-chip multi-threaded tasks, as well as supervises system activities such as keypad and front panel display control.

3.2 DSP-16 Processor

The CS7410 contains a proprietary digital signal processor (DSP) called DSP-16, which is optimized for audio and sound applications. In the CS7410, the DSP-16 assists with audio decoding and provides added functions such as surround sound and equalization. The DSP performs 16-bit simple integer operations, and has a 16-bit fixed point logic unit with a 32-bit accumulator.

There are 24 general-purpose registers, and eight independent address generation registers, featuring: post-increment ALU, linear and circular buffer operations, bit reverse ALU operations, and dual operand read from memory. The multiply-accumulator has single-cycle throughput, with two cycle latency. The DSP is optimized for bit packing and unpacking operations. The interface to main memory is designed for bursting flexible block sizes and skip counts.

3.3 Memory Control

The Memory Controller performs the arbitration functions for all the other modules in the CS7410, allowing access to internal ROM and SRAM, and to external ROM and DRAM. The Memory Controller services and arbitrates a number of clients and stores their code and/or data within the local memory. This arbitration and scheduling guarantees the allocation of sufficient bandwidth to the various clients. An optimal application will use only internal ROM and SRAM for code and data storage, which results in the best timing and lowest power consumption.

External DRAM may be used for runtime code storage or for ESP RAM. In both of these applications, the data throughput requirement is low, and the Memory Controller acts as a DMA engine to move data between external and internal memory with minimal power consumption. The internal ROM contains most of the code required for audio decoding and system functions.

Additional code can be stored in external ROM (managed by the Memory Controller) or a small serial ROM (controlled by GPIOs). The CS7410 also supports code storage in external FLASH with in-system write capability for customer code updates. Future firmware releases will provide a complete solution requiring no external ROM.

3.4 CD Interface

The CD Interface receives compressed or uncompressed (direct audio) data from the CD servo/read channel chip, performs descrambling and CRC checking, and writes the data to an internal FIFO. Additional C3 error decoding is done in software. The CD interface is compatible with all commonly used CD formats.

The CS7410 contains a hardware pattern matching circuit to scan the incoming CD data for a pattern of up to 64 bytes. This circuit is used to assist the Electronic Shock Protection function by quickly locating and matching the incoming data with data stored in the ESP RAM.

3.5 System Control Functions

The system control functions are used to coordinate the activities of the multiple processors, and to provide the supporting system operations. Two 32-bit communication registers are available for inter-processor communication, and 32 semaphore registers are used for resource locking. Three timers are available for general-purpose functions, as well as more specialized functions, such as watchdog timers and performance monitoring.

The large number of general purpose I/Os offers flexibility in system configurations. Three separate synchronous serial interfaces, conforming to industry-standard protocols, are available for a variety of system interface functions. Four general purpose software interrupts and twelve hardware interrupts help reduce peripheral overhead and improve UI responsiveness. Power-down control of the internal clocks is also possible. An internal PLL is used to generate the internal system and memory clocks as well as audio clocks for all supported sample rates.

3.6 Audio Output

Decoded audio data is written into an output FIFO in 16-, 18-, 20- or 24-bit PCM format. A flexible audio output stage can simultaneously output 4 channels of PCM data to external audio DACs, plus an independent IEC-958 encoded output. The IEC-958 output has fully programmable channel status (commercial), and provides a flexible solution to support all IEC-958 modes for user data. The audio output circuit contains an auto-mute detect circuit, which can generate internal or external mute controls

PCM FIFO data up to 18 bits can also be output by the on-board sigma-delta stereo modulator. The sigma-delta modulator yields a typical 85 dB signal-to-noise ratio with few external components required, resulting in a low-cost, low parts count analog front end. The modulator has a 32x upsampling filter, followed by a 32x interpolator, and finally a 5th-order Sigma-Delta modulator. The auto-mute circuit also works on the modulator output, and there are separate programmable attenuators for the modulator output and both PCM outputs.

4. PIN DESCRIPTION

4.1 Pin Identification

Figure 17 shows the CS7410 pins grouped by function, also showing the number of pins in each group.

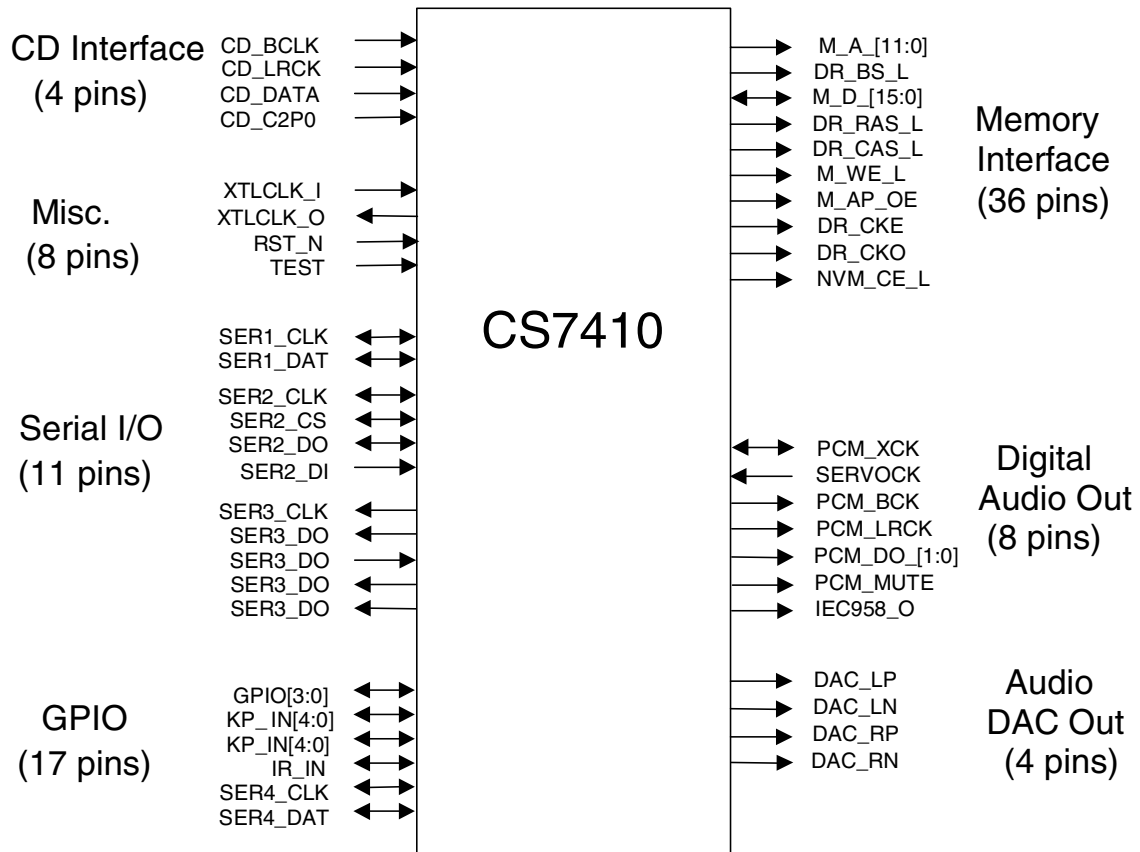

Figure 17. CS7410 Pin Identification

Table 6 lists the conventions used to identify the pin type and direction.pin assignments.

I: Input	B4: Bi-direction – 4mA drive
S: Schmitt trigger on input	D4: Bi-direction with 4mA open drain output
U: Pull up resistor	Pwr: +2.5V or +3.3V power supply voltage
O: Output	Gnd: Power supply ground
O4: Output – 4mA drive	Name_N: Low active
T4: High Z output – 4mA drive	Name_L: Low active
B: Bi-direction	-

Table 6. Pin Type and Direction Legend

Table 7 lists the pin number, pin name, and pin type for the 100-pin CS7410 package. For signal pins, the pin direction after reset is shown. The primary function and pin direction is shown for all signal pins. For some signal pins, a secondary function and direction are also shown.

Pin	Name	Type	Reset	Function #1	Dir	Function #2	Dir	Note
1	PLL_GND	Gnd	-	PLL Ground	-	-	-	-
2	PLL_1V8	Pwr	-	PLL Power	-	-	-	-
3	M_D_15	B4	I	DRAM Data[15]	B	NVMem Address[19]	O	-
4	M_D_14	B4	I	DRAM Data[14]	B	NVMem Address[18]	O	-
5	M_D_13	B4	I	DRAM Data[13]	B	NVMem Address[17]	O	-
6	M_D_12	B4	I	DRAM Data[12]	B	NVMem Address[16]	O	-
7	M_D_11	B4	I	DRAM Data[11]	B	NVMem Address[15]	O	-
8	M_D_10	B4	I	DRAM Data[10]	B	NVMem Address[14]	O	-
9	M_D_9	B4	I	DRAM Data[9]	B	NVMem Address[13]	O	-
10	M_D_8	B4	I	DRAM Data[8]	B	NVMem Address[12]	O	-
11	M_D_7	B4	I	DRAM Data[7]	B	NVMem Data[7]	B	-
12	CORE_1V8	Pwr	-	Core Power	-	-	-	-
13	M_D_6	B4	I	DRAM Data[6]	B	NVMem Data[6]	B	-
14	CORE_GND	Gnd	-	Core Ground	-	-	-	-
15	M_D_5	B4	I	DRAM Data[5]	B	NVMem Data[5]	B	-
16	IO_3V3	Pwr	-	I/O Power	-	-	-	-
17	XTLCLK_O	O	O	Oscillator Out	O	-	-	-
18	XTLCLK_I	I	I	Oscillator In	I	-	-	-
19	IO_GND	Gnd	-	I/O Ground	-	-	-	-
20	M_D_4	B4	I	DRAM Data[4]	B	NVMem Data[4]	B	-
21	M_D_3	B4	I	DRAM Data[3]	B	NVMem Data[3]	B	-
22	M_D_2	B4	I	DRAM Data[2]	B	NVMem Data[2]	B	-
23	M_D_1	B4	I	DRAM Data[1]	B	NVMem Data[1]	B	-
24	M_D_0	B4	I	DRAM Data[0]	B	NVMem Data[0]	B	-
25	M_A_11	B4	I	DRAM Address[11]	O	NVMem Address[11]	O	1
26	M_A_10	B4	I	DRAM Address[10]	O	NVMem Address[10]	O	1
27	M_A_9	B4	I	DRAM Address[19]	O	NVMem Address[9]	O	1
28	M_A_8	B4	I	DRAM Address[8]	O	NVMem Address[8]	O	1

Table 7. Pin Assignments

Pin	Name	Type	Reset	Function #1	Dir	Function #2	Dir	Note
29	M_A_7	B4	I	DRAM Address[7]	O	NVMem Address[7]	O	1, 3
30	M_A_6	B4	I	DRAM Address[6]	O	NVMem Address[6]	O	1, 3
31	M_A_5	B4	I	DRAM Address[5]	O	NVMem Address[5]	O	1, 3
32	M_A_4	B4	I	DRAM Address[4]	O	NVMem Address[4]	O	1, 3
33	M_A_3	B4	I	DRAM Address[3]	O	NVMem Address[3]	O	1, 3
34	M_A_2	T4	I	DRAM Address[2]	O	NVMem Address[2]	O	3
35	M_A_1	T4	I	DRAM Address[1]	O	NVMem Address[1]	O	3
36	M_A_0	T4	I	DRAM Address[0]	O	NVMem Address[0]	O	3
37	DR_RAS_L	T4	I	DRAM RAS_L	O	-	-	-
38	CORE_1V8	Pwr	-	Core Power	-	-	-	-
39	DR_CAS_L	T4	I	DRAM CAS_L	O	-	-	-
40	CORE_GND	Gnd	-	Core Ground	-	-	-	-
41	M_WE_L	T4	I	DRAM WE_L	O	NVM_WE_L	-	-
42	IO_GND	Gnd	-	I/O Ground	-	-	-	-
43	DR_CKO	T4	I	SDRAM CKO	O	-	-	-
44	IO_3V3	Pwr	-	I/O Power	-	-	-	-
45	DR_CKE	T4	I	SDRAM CKE	O	-	-	-
46	DR_BS_L	B4	I	SDRAM BS_L	O	NVMem Address[20]	-	1
47	M_AP_OE	B4	I	SDRAM AP, EDO DRAM OE_L	O	NVM_OE_L	-	1
48	NVM_CE_L	T4	I	NVM_CE_L	O	-	-	-
49	KP_IN_0	B4U	I	GPIO[19]	B	-	-	-
50	KP_IN_1	B4U	I	GPIO[20]	B	-	-	-
51	KP_IN_2	B4U	I	GPIO[21]	B	-	-	-
52	KP_IN_3	B4U	I	GPIO[22]	B	-	-	-
53	KP_IN_4	B4U	I	GPIO[23]	B	-	-	-
54	KP_OUT_0	B4	I	GPIO[24]	B	-	-	-
55	KP_OUT_1	B4	I	GPIO[25]	B	-	-	-
56	KP_OUT_2	B4	I	GPIO[26]	B	-	-	-
57	KP_OUT_3	B4	I	GPIO[27]	B	-	-	-

Table 7. Pin Assignments (Continued)

Pin	Name	Type	Reset	Function #1	Dir	Function #2	Dir	Note
58	KP_OUT_4	B4	I	GPIO[28]	B	-	-	-
59	IR_IN	B4S	I	GPIO[4]	B	-	-	-
60	SER1_CLK	D4S	I	Debug Port Clock	B	-	-	-
61	SER1_DAT	D4S	I	Debug Port Data	B	-	-	-
62	SER4_CLK	B4S	I	GPIO[5]	B	-	-	-
63	SER4_DAT	B4S	I	GPIO[6]	B	-	-	-
64	IO_GND	Gnd	-	I/O Ground	-	-	-	-
65	SER2_CLK	B4	I	Serial2 Clock	B	GPIO[7]	B	-
66	SER2_DI	B4	I	Serial2 Data In	B	GPIO[8]	B	-
67	SER2_DO	B4	I	Serial2 Data Out	B	GPIO[9]	B	-
68	SER2_CS	B4	I	Serial2 Chip Select	B	GPIO[10]	B	-
69	SER3_CLK	B4	I	Serial3 Clock	O	GPIO[11]	B	-
70	SER3_DO	B4	I	Serial3 Data Out	O	GPIO[12]	B	-
71	CORE_1V8	Pwr	-	Core Power	-	-	-	-
72	SER3_DI	B4	I	Serial3 Data In	I	GPIO[13]	B	
73	CORE_GND	Gnd	-	Core Ground	-	-	-	-
74	SER3_SS0	B4	I	Serial3 Chip Select0	O	GPIO[14]	B	
75	IO_3V3	Pwr	-	I/O Power	-	-	-	-
76	SER3_SS1	B4	I	Serial3 Chip Select1	O	GPIO[15]	B	
77	SERVOCK	B4	I	Servo Clock In	I	GPIO[17]	B	
78	PCM_XCK	B4	I	PCM_XCK	B	-	-	-
79	PCM_MUTE	B4	I	PCM_MUTE	O	GPO[4]	O	1
80	CD_C2P0	B4	I	CD_C2P0	I	GPIO[16]	B	
81	CD_BCLK	IS	I	CD_BCLK	I	-	-	-
82	CD_LRCK	I	I	CD_LRCK	I	-	-	-
83	CD_DATA	I	I	CD_DATA	I	-	-	-
84	DAC_LP	O4	O	$\Delta\Sigma$ DAC Left Positive Out	O	GPO[5]	O	
85	DAC_LN	O4	O	$\Delta\Sigma$ DAC Left Negative Out	O	GPO[6]	O	
86	IO_GND	Gnd	-	I/O Ground	-	-	-	-

Table 7. Pin Assignments (Continued)

Pin	Name	Type	Reset	Function #1	Dir	Function #2	Dir	Note
87	DAC_RP	O4	O	$\Delta\Sigma$ DAC Right Positive Out	O	GPO[7]	O	
88	DAC_3V3	Pwr	-	$\Delta\Sigma$ DAC I/O Power	-	-	-	-
89	DAC_RP	O4	O	$\Delta\Sigma$ DAC Right Negative Out	O	GPO[8]	O	
90	RST_N	IS	I	Reset_L	I	-	-	-
91	TEST	I	I	Manufacturing Test	I	-	-	-
92	PCM_BCK	B4	O	PCM_BCK	O	GPO[0]	O	1
93	PCM_LRCK	B4	O	PCM_LRCK	O	GPO[1]	O	1
94	PCM_DO_0	B4	O	PCM_Dout[0]	O	GPO[2]	O	2
95	PCM_DO_1	B4	O	PCM_Dout[1]	O	GPO[3]	O	1
96	IEC958_O	B4	I	IEC-958 Out	O	GPIO[18]	B	
97	GPIO_0	B4	I	GPIO[0]	B	-	-	-
98	GPIO_1	B4	I	GPIO[1]	B	PWM_OUT	O	
99	GPIO_2	B4	I	GPIO[2]	B	-	-	-
100	GPIO_3	B4	I	GPIO[3]	B	-	-	-

Table 7. Pin Assignments (Continued)

1. Optional pull up or pull down resistor may be connected to configure internal ROM program
2. Required external resistor required to select processor boot from internal ROM (pull down) or external ROM (pull up).
3. Drives for a short time after reset, then reverts to high impedance

4.2 Miscellaneous Pins

These pins described in Table 8 are used for used for basic functions such as clocking, reset and infrared receiver interface. The main system clock can be derived from an external crystal connected between the XTLCLK_I and XTLCLK_O pins, or can be received from the CD servo chip via the XTLCLK_I pin. The CS7410 can accommodate a variety of input frequencies, such as 44.1 KHz x 256, x 384, or x 512.

Pin	Signal Name	Type	Description
17	XTLCLK_O	O	Crystal output
18	XTLCLK_I	I	Crystal input, or oscillator input
90	RST_N	I	Asynchronous reset input, active low
91	TEST	I	Manufacturing test, tie to ground

Table 8. Miscellaneous Interface Pins

4.3 Serial Interface Pins

The CS7410 Serial Interface pins are described in Table 9. CS7410 has three dedicated serial ports, each with different protocols. The 2-wire serial port (SER1) supports industry standard protocols. This port is typically used for debug, with the CS7410 as the slave. The slave chip select address is programmable, and

defaults to a 7-bit value of 0x1B. A second serial controller (SER2) supports industry standard 3-wire and 4-wire protocols. In master mode, this interface can control a front panel or a small non-volatile memory. In slave mode, it can operate under control of an external processor, for example, in a combination unit. The third serial port (SER3) is a 5-wire master device optimized for reading CD subcodes from the servo chip, and can also be used a general-purpose serial port.

Pin	Signal Name	Type	Description
60	SER1_CLK	B	Debug port serial clock
61	SER1_DAT	B	Debug port serial data
65	SER2_CLK	B	Clock for 4-wire serial port (output for master mode, input for slave mode)
66	SER2_DI	I	Input data for 4-wire serial port
67	SER2_DO	B	Output data for 4-wire serial port – may function as bidirectional data in 3-wire mode.
68	SER2_CS	B	Chip select for 4-wire serial port (output if master, input if slave mode). Can also be used as bidirectional ready line.
69	SER3_CLK	O	Clock output
70	SER3_DO	O	Data output – up to 32 bits per transfer.
72	SER3_DI	I	Data input – up to 96 bits per transfer.
74	SER3_SS0	O	Slave select for first peripheral (programmable polarity)
76	SER3_SS1	O	Slave select for second peripheral (programmable polarity)

Table 9. Serial Interface Pins

4.4 SDRAM / DRAM Interface

These pins are used to interface the CS7410 with external synchronous or EDO DRAMs. Data widths of 4 to 16 bits are supported. The CS7410 supports word or block transfers (partial word transfers are not required). Table 10 gives instructions on how to interface to any particular configuration of SDRAM. Table 11 gives pin definitions for interfacing to EDO DRAM.

Pin	Signal Name	Type	Description
3, 4, 5, 6, 7, 8, 9, 10, 11, 13, 15, 20, 21, 22, 23, 24	DRAM Data[15..0]	B	Memory Data Bus.
25, 26, 27, 28, 29, 30, 31, 32, 33, 34, 35, 36	DRAM Address[11..0]	O	Memory Address Bus. Connect in order starting with DR_Addr[0] to all RAM address pins not already connected to DR_BS_L or DR_AP.
37	DR_RAS_L	O	Memory Row Address Strobe
39	DR_CAS_L	O	Memory Column Address Strobe
41	M_WE_L	O	Memory Write Enable

Table 10. SDRAM Interface

Pin	Signal Name	Type	Description
43	DR_CKO	O	SDRAM Clock
45	DR_CKE	O	SDRAM Clock Enable
46	DR_BS_L	O	Bank Selection. Always connect to RAM BS or BS0 pin.
47	M_AP_OE	O	Memory Auto Pre-charge. Always connect to RAM AP pin.

Table 10. SDRAM Interface (Continued)

Pin	Signal Name	Type	Description
3, 4, 5, 6, 7, 8, 9, 10, 11, 13, 15, 20, 21, 22, 23, 24	DRAM Data[15..0]	B	Memory Data Bus.
25, 26, 27, 28, 29, 30, 31, 32, 33, 34, 35, 36	DRAM Address[11..0]	O	Memory Address Bus.
37	DR_RAS_L	O	Memory Row Address Strobe
39	DR_CAS_L	O	Memory Column Address Strobe
41	M_WE_L	O	Memory Write Enable
47	M_AP_OE	O	Memory Output Enable

Table 11. EDO DRAM Interface

4.5 ROM/NVRAM Interface

The ROM/NVRAM Interface pins are described in Table 12. This interface connects to the non-volatile memory that contains the firmware. The memory could be ROM, NVRAM (FLASH), EEPROM, or any combination of these memory types. This interface can also connect to SRAM that would emulate a ROM on a development system. The bus width is always 8 bits. Most of these pins are shared with the DRAM interface, which operates simultaneously with the ROM/NVRAM interface. A number of pins are defined to accept configuration input at power-up (see Table 7), allowing different branches to be taken in the firmware. A configuration resistor is required on pin PCM_DO_0 to select whether the processor will boot from internal or external ROM.

Pin	Signal Name	Type	Description
11, 13, 15, 20, 21, 22, 23, 24	NVMem Data[7..0]	B	Memory Data Bus (shared with bits [7:0] of DRAM data bus).
25, 26, 27, 28, 29, 30, 31, 32, 33, 34, 35, 36	NVM_Addr[11..0]	O	Memory Address Bus[11..0] (shared with DRAM address bus)
3, 4, 5, 6, 7, 8, 9, 10	NVM_Addr[19..12]	O	Memory Address Bus[19..12] (shared with bits [15..8] of DRAM data bus).
46	NVM_Addr[20]	O	Memory Address Bus[20] (DRAM BS_L pin).
41	NVM_WE_L	O	NVRAM Write Enable (shared with DRAM WE_L pin)
47	NVM_OE_L	O	NVRAM Write Enable (shared with DRAM WE_L pin)
48	NVM_CE_L	O	ROM/NVRAM Chip Enable.

Table 12. ROM/NVRAM Interface

4.6 Digital Audio Output Interface

The Digital Audio Output Interface pins are described in Table 13. This is the audio PCM interface that connects to an audio PCM DAC. The sample rate and the size of the samples are programmable to accommodate any commercially available DAC. The CS7410 has two data output pins, for up to 4 channels of PCM output, and a separate output pin to simultaneously output IEC-958 encoded data (either compressed or uncompressed).

Pin	Signal Name	Type	Description
78	PCM_XCK	B	Audio 256x/384x/512x Clock input or output to Serial DAC. When output, it's generated from CS7410 internal PLL.
77	SERVOCK	I	Optional source of Audio 256x/384x/512x Audio Clock. May be used for CD direct audio to match input and output clocks.
79	PCM_MUTE	O	Audio Mute control to external DAC. Polarity is programmable and is three-stated at power up.
92	PCM_BCK	O	Audio Bit Clock output to serial DAC. Polarity is programmable.
93	PCM_LRCK	O	Audio Out Left/Right Clock to serial DAC.
94	PCM_DO_0	O	Audio Serial PCM Data Out[0].
95	PCM_DO_1	O	Audio Serial PCM Data Out[1].
96	IEC958_O	O	IEC-958 Output

Table 13. Audio Output Interface

4.7 $\Delta\Sigma$ Modulator Interface

The $\Delta\Sigma$ Interface pins are described in Table 14. The CS7410 contains a stereo Delta-Sigma ($\Delta\Sigma$) modulator, which outputs two differential digital signals on four pins. These outputs are design to drive an external op-amp based integrator circuit (contact Cirrus Logic Applications Engineering for details).

Pin	Signal Name	Type	Description
84	DAC_LP	O	$\Delta\Sigma$ left channel, positive output
85	DAC_LN	O	$\Delta\Sigma$ left channel, negative output
87	DAC_RP	O	$\Delta\Sigma$ right channel, positive output
89	DAC_RN	O	$\Delta\Sigma$ right channel, positive output

Table 14. $\Delta\Sigma$ Output Interface

4.8 CD Interface

The CD Interface pins are described in Table 15. This interface is used to read serial CD data from a CD servo/read channel chip. The interface supports all standard formats, including 16 MHz, 24 MHz and 32 MHz clocks per container. Control of the CD servo chip is done by the RISC processor using GPIOs, and CD subcode data is read using the dedicated serial interface (SER3).

Pin	Signal Name	Type	Description
81	CD_BCLK	I	CD clock input – polarity is programmable
82	CD_LRCK	I	CD left-right clock input
83	CD_DATA	I	CD serial data input
80	CD_C2P0	I	CD error signaling input

Table 15. CD Interface

4.9 General Purpose Input/Output (GPIO)

The CS7410 provides a number of General Purpose Input/Output (GPIO) pins, each with individual output three-state controls, and a number of General Purpose Output (GPO) pins. Table 16 shows the 17 dedicated GPIO pins. A naming scheme for these pins was chosen to encourage system designers to adhere to standardized pin usage. Table 17 shows the GPIO and GPO pins that can be redefined from other functions. For redefined pins, mode control register bits select the normal function or GPIO/GPO function for the pins. Table 17 also indicates which mode bit controls each pin.

Pin	Signal Name	Type	Description
100, 99, 98, 97	GPIO[3:0]	B	4 General purpose I/O on dedicated pins
53, 52, 51, 50, 49	KP_IN[4:0]	B	5 General purpose I/O on dedicated pins
58, 57, 56, 55, 54	KP_OUT[4:0]	B	5 General purpose I/O on dedicated pins
59	IR_IN	B	General purpose I/O on dedicated pin
62	SER4_CLK	B	General purpose I/O on dedicated pin
63	SER4_DAT	B	General purpose I/O on dedicated pin

Table 16. Dedicated General Purpose I/O Pins

Pin	Signal Name	Type	Description
65	SER2_CLK	B	GPIO controlled by Mode bit 2
67	SER2_DO	B	GPIO controlled by Mode bit 2
68	SER2_CS	B	GPIO controlled by Mode bit 2
66	SER2_DI	B	GPIO controlled by Mode bit 3
69	SER3_CLK	B	GPIO controlled by Mode bit 4
70	SER3_DO	B	GPIO controlled by Mode bit 4
72	SER3_DI	B	GPIO controlled by Mode bit 4
74	SER3_SS0	B	GPIO controlled by Mode bit 4
76	SER3_SS1	B	GPIO controlled by Mode bit 5
80	CD_C2P0	B	GPIO controlled by Mode bit 6
77	SERVOCK	B	GPIO controlled by Mode bit 7
92	PCM_BCK	O	GPO controlled by Mode bit 8
93	PCM_LRCK	O	GPO controlled by Mode bit 9
94	PCM_DO_0	O	GPO controlled by Mode bit 10
95	PCM_DO_1	O	GPO controlled by Mode bit 11
79	PCM_MUTE	O	GPO controlled by Mode bit 12

Table 17. Redefined General Purpose Pins

Pin	Signal Name	Type	Description
84	DAC_LP	O	GPO controlled by Mode bit 13
85	DAC_LN	O	GPO controlled by Mode bit 13
87	DAC_RP	O	GPO controlled by Mode bit 13
89	DAC_RN	O	GPO controlled by Mode bit 13
96	IEC958_O	B	GPIO controlled by Mode bit 14

Table 17. Redefined General Purpose Pins (Continued)

4.10 Power and Ground

Table 18 describes the power and ground pins. The CS7410 requires 3 different types of power supplies for the PLLs, internal logic, and IO pins. The PLLs and internal logic use 1.8 V supply voltage. The IO pins use 3.3 V supply voltage. An optional separate supply can be used to provide clean 3.3 V to the Sigma-Delta DACs digital output pads. It is recommended that you use good layout techniques to provide isolation between the supply types on the board. Contact Cirrus Logic applications engineering for layout guidelines.

Pin	Signal Name	Type	Description
1	PLL_GND	-	Ground for internal PLLs
2	PLL_1V8	-	1.8V for internal PLLs
14, 40, 73	CORE_GND	-	Ground for internal core logic
12, 38, 71	CORE_1V8	-	1.8V for internal core logic
19, 42, 64, 86	IO_GND	-	Ground for Digital I/Os
16, 44, 75	IO_3V3	-	3.3V for Digital I/Os
88	DAC_3V3	-	3.3V for Sigma Delta DAC Digital I/Os

Table 18. Power and Ground

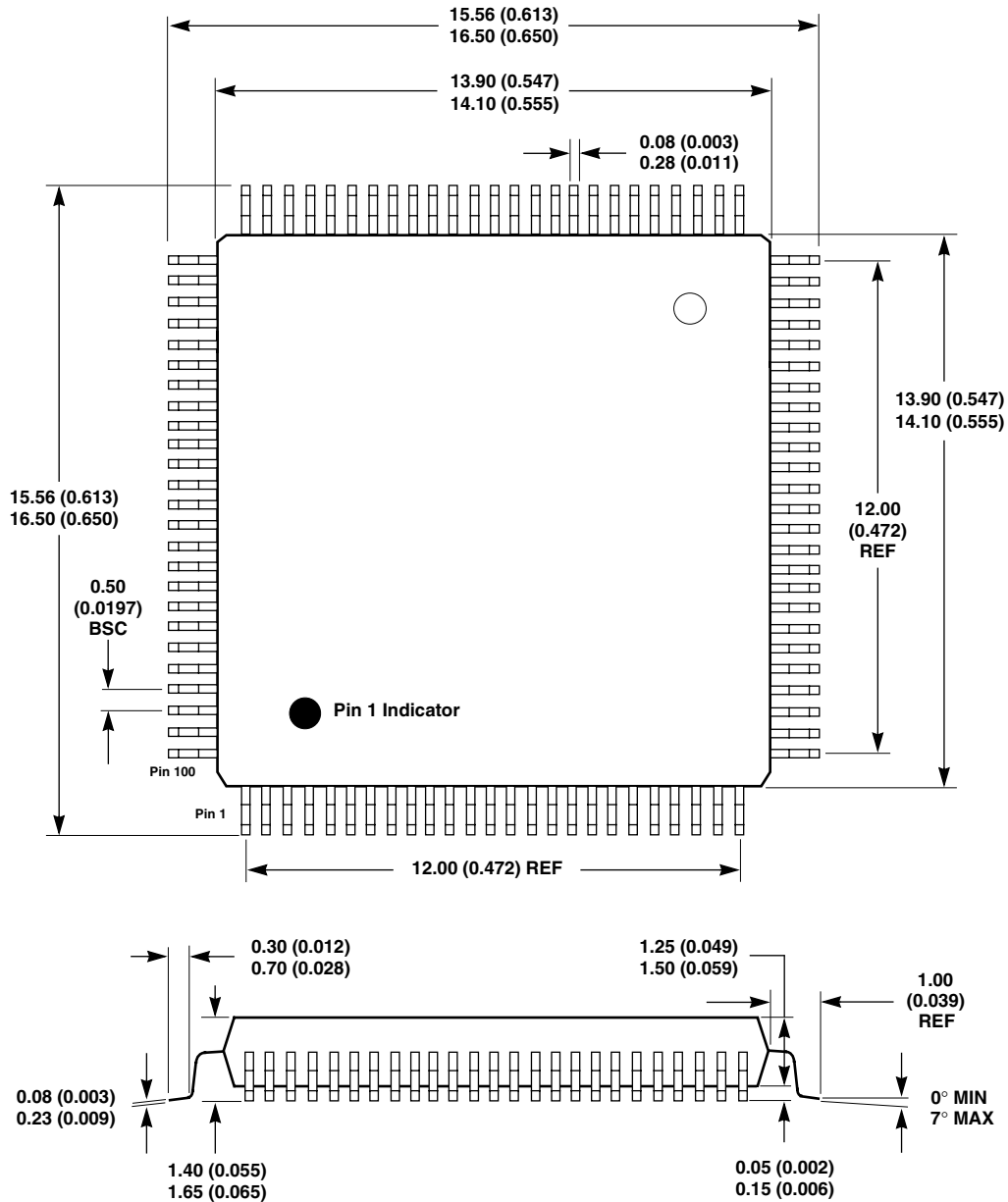
5. 100-PIN LQFP PACKAGE SPECIFICATIONS (14 X 14 X 1.4 mm)

NOTES:

- 1) Dimensions are in millimeters (inches), and controlling dimension is millimeter.
- 2) Package body dimensions do not include mold protrusion, which is 0.25 mm (0.010 in).
- 3) Pin 1 identification may be either ink dot or dimple.
- 4) Package top dimensions can be smaller than bottom dimensions by 0.20 mm (0.008 in).
- 5) The lead width with plating dimension does not include a total allowable dambar protrusion of 0.08 mm (at maximum material condition).
- 6) Ejector pin marks in molding are present on every package.

Figure 18. 100-Pin LQFP Package (14 X 14 X 1.4 mm)

6. REVISION HISTORY

Table 19. Revision History

Revision	Date	Changes
1	August 2002	Initial release
2	May 2003	Update AC specifications
3	22 June 2004	Add lead-free/industrial part number, delete MFQP packaging

Contacting Cirrus Logic Support

For all product questions and inquiries contact a Cirrus Logic Sales Representative.

To find one nearest you go to www.cirrus.com

IMPORTANT NOTICE

"Preliminary" product information describes products that are in production, but for which full characterization data is not yet available. Cirrus Logic, Inc. and its subsidiaries ("Cirrus") believe that the information contained in this document is accurate and reliable. However, the information is subject to change without notice and is provided "AS IS" without warranty of any kind (express or implied). Customers are advised to obtain the latest version of relevant information to verify, before placing orders, that information being relied on is current and complete. All products are sold subject to the terms and conditions of sale supplied at the time of order acknowledgment, including those pertaining to warranty, patent infringement, and limitation of liability. No responsibility is assumed by Cirrus for the use of this information, including use of this information as the basis for manufacture or sale of any items, or for infringement of patents or other rights of third parties. This document is the property of Cirrus and by furnishing this information, Cirrus grants no license, express or implied under any patents, mask work rights, copyrights, trademarks, trade secrets or other intellectual property rights. Cirrus owns the copyrights associated with the information contained herein and gives consent for copies to be made of the information only for use within your organization with respect to Cirrus integrated circuits or other products of Cirrus. This consent does not extend to other copying such as copying for general distribution, advertising or promotional purposes, or for creating any work for resale.

CERTAIN APPLICATIONS USING SEMICONDUCTOR PRODUCTS MAY INVOLVE POTENTIAL RISKS OF DEATH, PERSONAL INJURY, OR SEVERE PROPERTY OR ENVIRONMENTAL DAMAGE ("CRITICAL APPLICATIONS"). CIRRUS PRODUCTS ARE NOT DESIGNED, AUTHORIZED OR WARRANTED FOR USE IN AIRCRAFT SYSTEMS, MILITARY APPLICATIONS, PRODUCTS SURGICALLY IMPLANTED INTO THE BODY, LIFE SUPPORT PRODUCTS OR OTHER CRITICAL APPLICATIONS (INCLUDING MEDICAL DEVICES, AIRCRAFT SYSTEMS OR COMPONENTS AND PERSONAL OR AUTOMOTIVE SAFETY OR SECURITY DEVICES). INCLUSION OF CIRRUS PRODUCTS IN SUCH APPLICATIONS IS UNDERSTOOD TO BE FULLY AT THE CUSTOMER'S RISK AND CIRRUS DISCLAIMS AND MAKES NO WARRANTY, EXPRESS, STATUTORY OR IMPLIED, INCLUDING THE IMPLIED WARRANTIES OF MERCHANTABILITY AND FITNESS FOR PARTICULAR PURPOSE, WITH REGARD TO ANY CIRRUS PRODUCT THAT IS USED IN SUCH A MANNER. IF THE CUSTOMER OR CUSTOMER'S CUSTOMER USES OR PERMITS THE USE OF CIRRUS PRODUCTS IN CRITICAL APPLICATIONS, CUSTOMER AGREES, BY SUCH USE, TO FULLY INDEMNIFY CIRRUS, ITS OFFICERS, DIRECTORS, EMPLOYEES, DISTRIBUTORS AND OTHER AGENTS FROM ANY AND ALL LIABILITY, INCLUDING ATTORNEYS' FEES AND COSTS, THAT MAY RESULT FROM OR ARISE IN CONNECTION WITH THESE USES.

MPEG Layer-3 (MP3) audio coding technology licensed from Fraunhofer Gesellschaft and Thomson multimedia. Supply of this product only conveys a license for personal, private and non-commercial use. Supply of this product does not convey a license under the relevant intellectual property of Thomson multimedia and/or Fraunhofer Gesellschaft nor imply any right to use this product in any finished end user or ready-to-use final product. An independent license for such use is required. For details, please visit <http://www.mp3licensing.com>.

Windows Media is a registered trademark of Microsoft Corporation. The product includes technology owned by Microsoft Corporation and cannot be used or distributed without a license from Microsoft Licensing, Inc.

AAC is a trademark of Dolby Laboratories, Inc.

Cirrus Logic, Cirrus, and the Cirrus Logic logo designs are trademarks of Cirrus Logic, Inc. All other brand and product names in this document may be trademarks or service marks of their respective owners.